

GRANDE ARTEMIS

A New Era in 3.2m Wide-Format Printing.
Experience Revolutionary Performance with Speeds.





Introduction to DGI

Since 1985, DGI has been a prominent presence in the global digital printing industry, steadily growing over the years. To generate higher and more sustainable customer value, we will persistently stay the course, unwavering in our pursuit of excellence in engineering, development, and sales.



~1997

Cutting Plotter
Pen Plotter
Drafting Machine
Parallel Ruler

~2000

Sign & Graphics
Printer

~2010

Dye Sublimation
Printer

~2015

Direct Textile
Printer

~2019

Food Printer

~2022

Package Printer

~2023

Acquired

~2025

Establishment
of Full Industrial
Printing Portfolio

Revolutionary 3.2m Printing,
Grande Scale, Supreme Velocity

ARTEMIS GRANDE

Over 80 Countries

DGI has been expanding its presence to approximately 80 countries. As of last year, the service was being operated in various countries, including Italy, the UK, Saudi Arabia, and the US. Now, more than 3,600 companies are estimated to have been using it.

DGI HEADQUARTERS

52, Cheongdam-Ro, Yangju-si, Gyeonggi-do,
Korea
TEL +82-31-820-8900

DGI GLOBAL SALES OFFICE

11F, Simon Tower, 15 Teheran-ro 84-gil,
Gangnam-gu, Seoul
TEL +82-2-820-8900

DGI Europe

Via Giuseppe Garibaldi, 151, 20833 Giussano MB, Italy
TEL +39-340-38-70-459

DGI USA

27 Spectrum Pointe Drive, Suites 311 and 312,
Lake Forest, CA, USA
TEL +1-949-942-1885

DGI CHINA

Outlets130-104, Hengdayulanguoji, No.702 Shanhe Road, Chengyang District,
Qingdao City, Shandong Province, CHINA
TEL +86-187-6390-1188

Revolutionary 3.2m Printing,
Grande Scale, Supreme Velocity

ARTEMIS GRANDE

SPC

Stylish Penetration Control

SPC is DGI's proprietary technology that utilizes a specially formulated "Stylish Penetration Control" liquid to enhance ink penetration, resulting in superior color uniformity and Perfect double-sided results for flags.



PENETRATION WITHOUT SPC

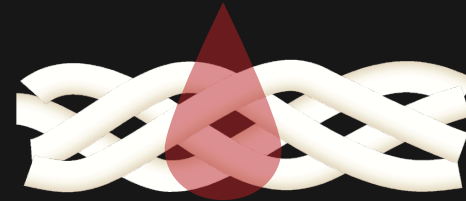

PENETRATION WITH SPC

WITHOUT SPC

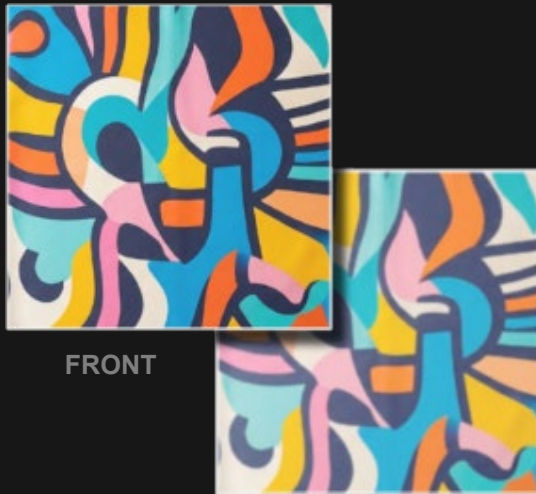

FRONT

BACK

WITH SPC

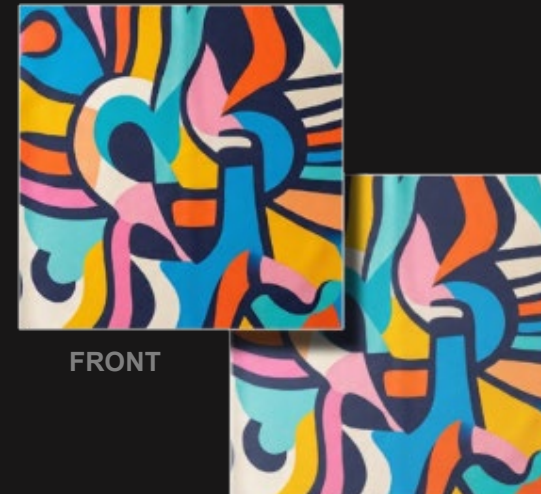

FRONT

BACK

Revolutionary 3.2m Printing,
Grande Scale, Supreme Velocity

ARTEMIS GRANDE

Introducing ARTEMIS GRANDE

The definitive 3.2-meter direct-to-fabric printer, engineered to deliver revolutionary performance and unlock new revenue opportunities for your business.



**Unrivaled
Performance**

New benchmark
in speed and
productivity



**Intelligent
Engineering**

Smarter features for
versatility and
quality



**Economic
Advantage**

Maximizing Efficiency
through Inline Systems

Revolutionary 3.2m Printing,
Grande Scale, Supreme Velocity

ARTEMIS GRANDE

Technological advancements of the ARTEMIS GRANDE



High Production Speed

200m² /h
(4C, 360x1200
2pass)



Printing Resolution

720 x
3600 dpi



7pl Smallest Droplet and Variable Dots



Ink Configuration

4, 6, 8 Colors
+
Optional SPC



Max Media Thickness

15mm



Advanced Printheads

Ricoh gen5
X
12 Printheads



Max Print Width

3,200mm

Revolutionary 3.2m Printing,
Grande Scale, Supreme Velocity

ARTEMIS GRANDE

Performance

4 color

200 m²/h (2pass)

6, 8color

150 m²/h (3pass)

Engineered for Pure Speed

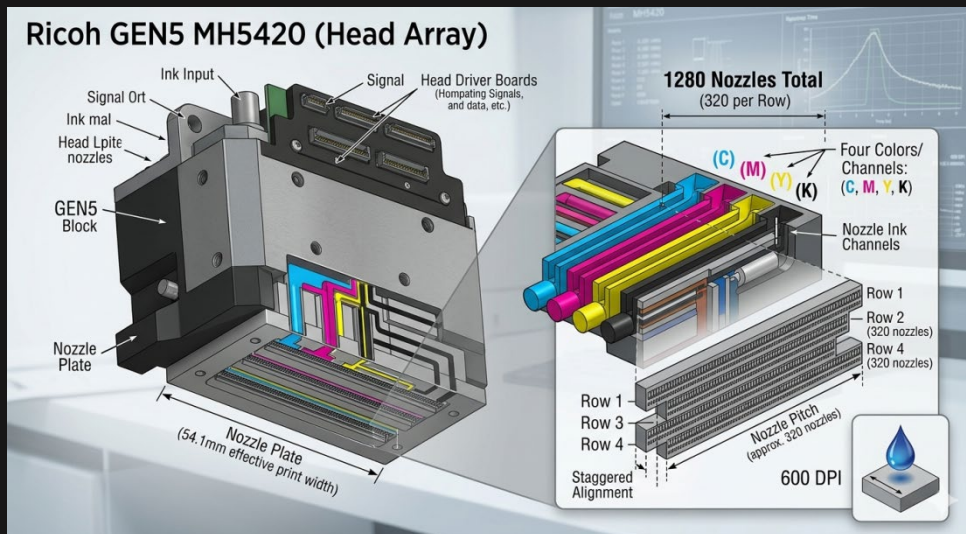

Advanced Head Array

4x3 staggered layout of 12 Ricoh Gen5 print heads maximizes print width coverage with every pass.

Linear Motor Carriage

X-axis driven by quiet, high-precision linear motor eliminates pulley replacements, ensuring consistent printing at high speeds.

Multiple Print Modes

3-Pass Mode achieves up to 150 m²/h production speed.

Revolutionary 3.2m Printing,
Grande Scale, Supreme Velocity

ARTEMIS GRANDE

Intelligence in Every Detail

Automatic Carriage Height

Adjusts up to 15mm automatically, enabling high-quality printing on thick materials like carpets without manual intervention.

Expanded Color Gamut & SPC

Supports 4, 6, and 8 color configurations, including optional Stylish penetration liquid for vibrant brand colors.

Enhanced Media Handling

Superior feeding system ensures reliable, precise media transport for consistent print quality across entire roll.



Lower Investment

~50% reduction broadens market access



Increased Productivity

Up to 150 m²/h maximizes ROI



Competitive Edge

No compromise on quality or features

Revolutionary 3.2m Printing,
Grande Scale, Supreme Velocity

ARTEMIS GRANDE

Print on More Surfaces Than Ever Before

Automatic Carriage Height Adjustment

Feature: Clearance up to 15mm enables printing on thick and textured media.

Advantage: Print directly onto carpets, rugs, and challenging textiles impossible for standard printers.

Benefit: Expand into high-margin markets like custom flooring, home decor, and specialty textiles.



Brilliant Color : Vibrancy and Flexibility in Every Drop

Feature

Flexible ink configurations with up to **8 colors**, including Light Cyan, Light Magenta, Orange, and Blue, plus optional Stylish Penetration Liquid.

Advantage

Achieve exceptionally wide color gamut for photorealistic quality, smooth gradients, and precise brand color matching.

A New Spectrum of Applications

Power and precision unlock opportunities across demanding textile printing segments. From high-volume signage to custom home textiles, one machine provides versatility to capture it all.



Soft Signage & Display Graphics

Capitalize on \$600M+ advertising print market with speed, color vibrancy, and 3.2m width for high-impact displays.



Home & Technical Textiles

15mm automated head clearance enables printing on thick materials like carpets, opening custom decor market.

Revolutionary 3.2m Printing,
Grande Scale, Supreme Velocity

ARTEMIS GRANDE

Design : The shape of innovation

Artemis Grande introduces a new design identity for DGI.
Inspired by grace and power, flowing curves and refined interface represent harmony of form and function.



**Distinctive
Identity**

Unique aesthetic
that stands out
on production
floor



**User-Centric
Ergonomics**

Key touchpoints
positioned for ease
of use and
maintenance



DGI Tone & Manner

Creating cohesive
family look design

Revolutionary 3.2m Printing,
Grande Scale, Supreme Velocity

ARTEMIS GRANDE

Design Concept : Sophisticated Elegance

ARTEMIS GRANDE is an innovative digital printer that combines sophisticated, fluid curves with ergonomic engineering to move beyond traditional industrial aesthetics and maximize both user convenience and safety.

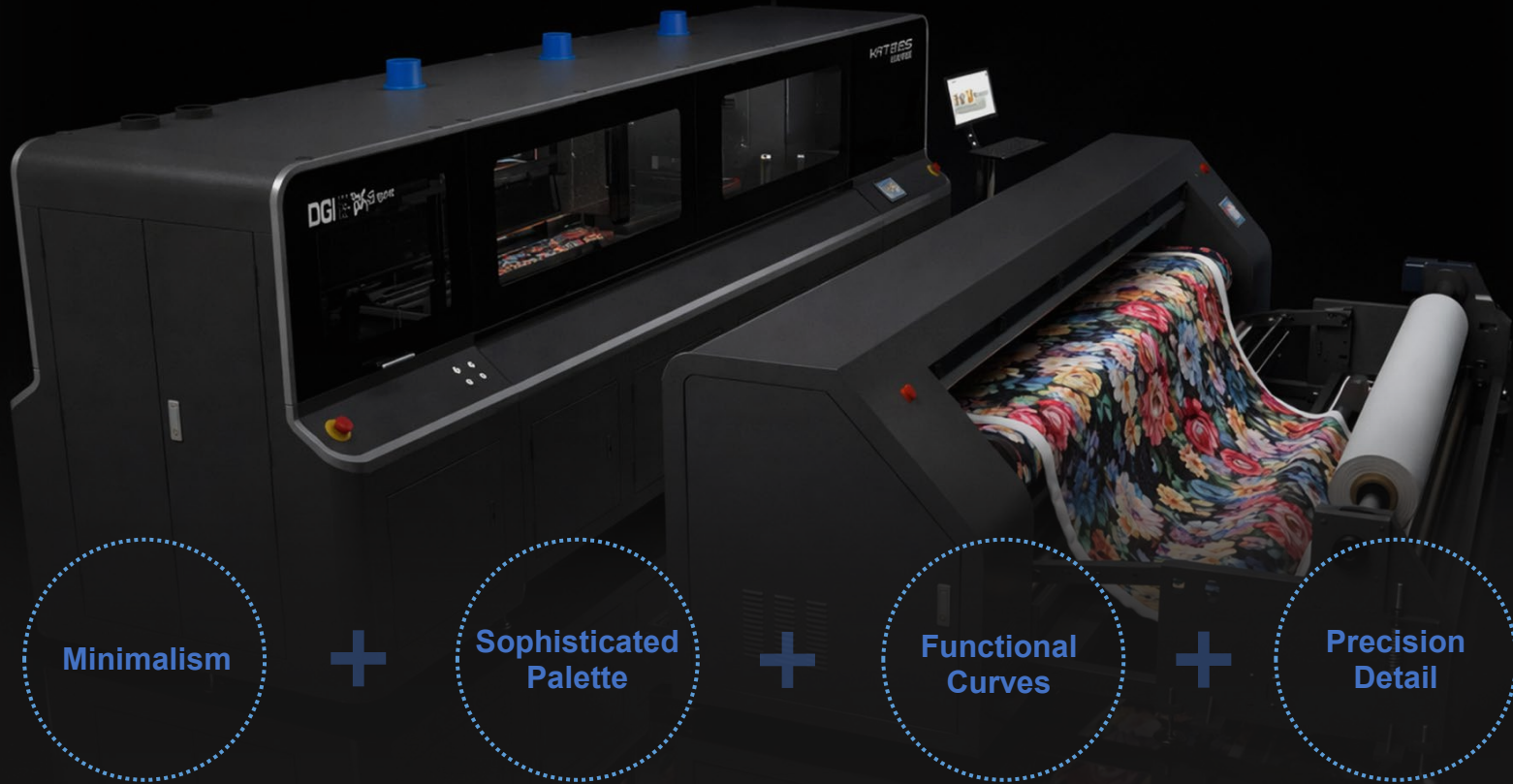

LEFT SIDE VIEW



FRONT VIEW

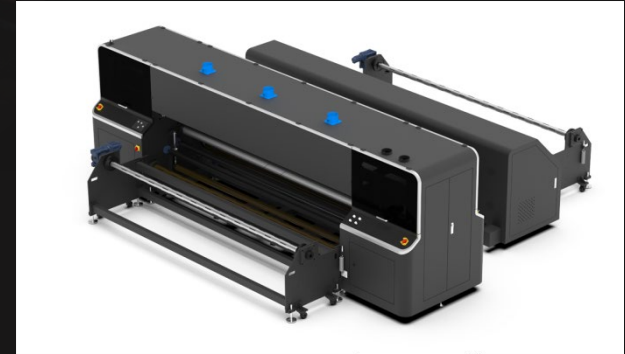

REAR VIEW

ARTEMIS GRANDE Production Line Configuration



UNWINDER

PRINTER

SUB PLATE

FIXATION

WINDER

Revolutionary 3.2m Printing,
Grande Scale, Supreme Velocity

ARTEMIS GRANDE

Main key features

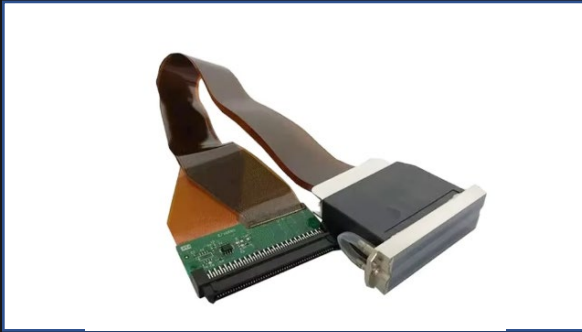

More Precise Printhead Control

To ensure high-resolution printing, the Ricoh Printhead is equipped with 1,280 nozzles, enabling it to produce droplets as small as 7pl.

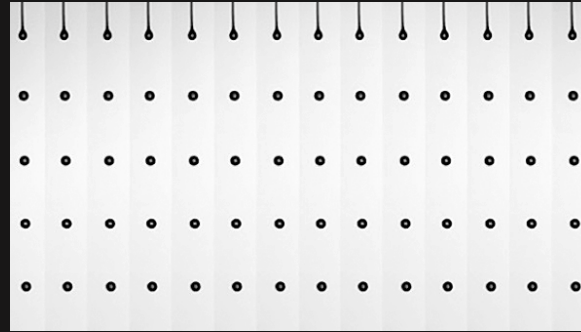

Dedicated Waveform

The dedicated waveform, developed by DGI, enables us to respond to customers' demands for quality graphics and design in various ways.

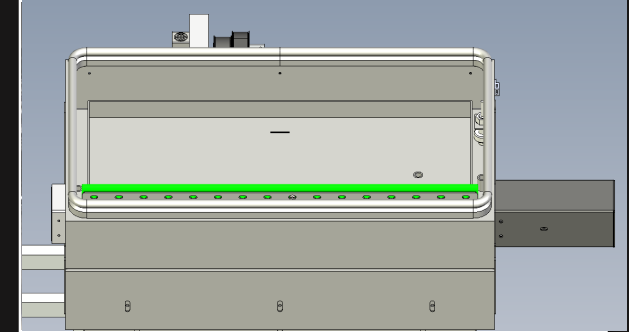

Advanced Cleaning System

The entire printhead can be wiped clean with a single blade stroke, ensuring optimal maintenance efficiency.

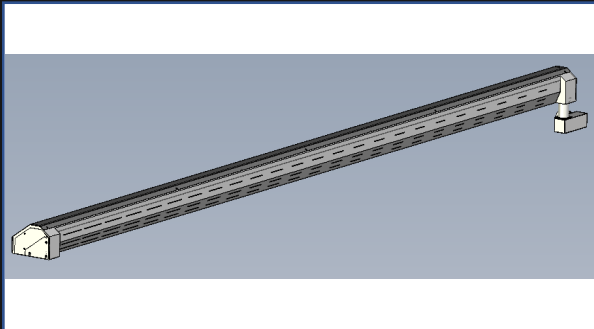

Mist Removal in Main Body & Head Carriage

Dual dust removal systems prevent contamination of both the media and peripherals by effectively removing ink mist and dust generated during printing.

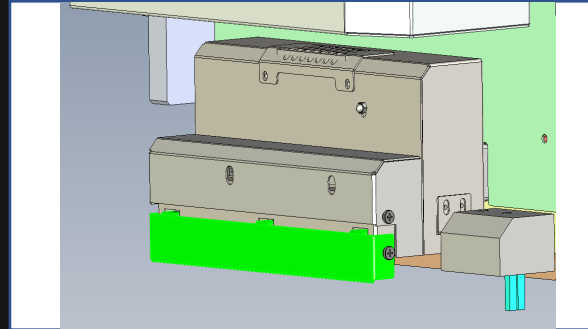

Head Collision Protection System

Bi-directional anti-collision sensors are located on both the left and right sides of the carriage to detect and prevent potential damage.

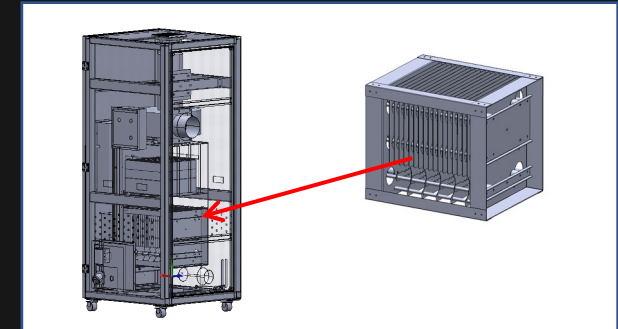

Oil Mist Removal System (Fume Buster)

Fine particulate oil mist is effectively removed through an **electromagnetic adsorption method**, maintaining a clean working environment.

Revolutionary 3.2m Printing,
Grande Scale, Supreme Velocity

ARTEMIS GRANDE

Main key features

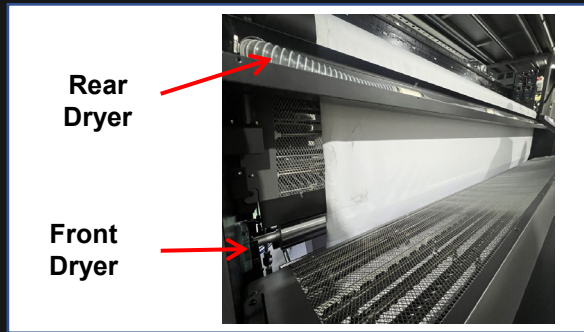

Dual Dryer System (Front & Rear)

Dual heaters are arranged in a 2-stage front and rear configuration to achieve powerful and consistent drying performance.

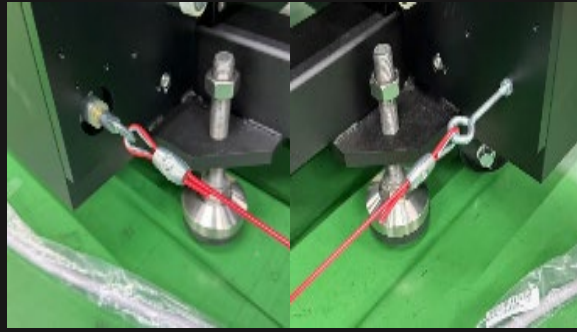

Safety Rope Switch

For maximum operator safety, emergency stop rope switches are located at both the front and rear of the machine.

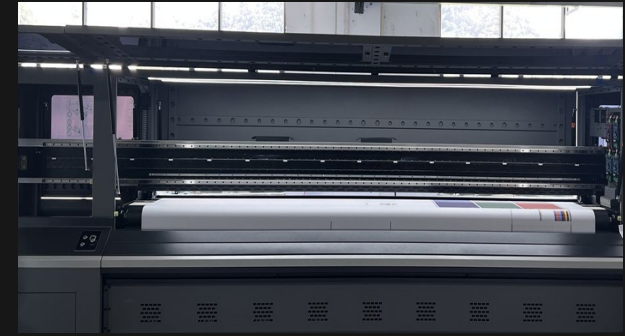

Linear Motor & Metal Encoder

The application of a high-precision linear motor and metal encoder scale provides superior stability and accurate output.

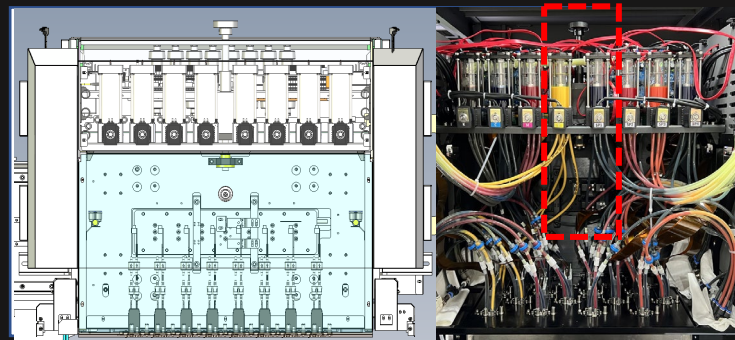

Z-Axis Carriage Motion

The carriage height can be adjusted along the Z-axis to accommodate various media thicknesses (up to **15mm**).

Revolutionary 3.2m Printing,
Grande Scale, Supreme Velocity

ARTEMIS GRANDE

Specification

Printing	Ink	Printing Speed	
Print Head Ricoh 12 Heads / 3Stagger	Water based Dye Sublimation Yellow, Magenta, Cyan, Black, Orange, Turquoise, Light Cyan, Light Magenta, SPC	4C 360X1200dpi 2pass 200 m ² /h	6/8C 360X900dpi 3pass 150 m ² /h
Ink Type Disperse / Direct Sublimation	Ink Capacity 5L	360X1800dpi 3pass 150 m ² /h	360X1200dpi 4pass 115 m ² /h
Number of Color 8		360X2400dpi 4pass 110 m ² /h	360X1800dpi 6pass 76 m ² /h
Maximum Print Resolution 720X3,600dpi			360X2400dpi 8pass 58 m ² /h
Max Print Width 3,200mm			
Print Mode Bi-Direction/Uni-Direction			

Revolutionary 3.2m Printing,
Grande Scale, Supreme Velocity

ARTEMIS GRANDE

Specification

Media

Media Drive
Roll to Roll

Maximum Media Width
3,250mm

Maximum Media Load(Basic Specifications)
Diameter : 350mm, Weight : 150kg

Maximum Media Load(Optional Specifications)
Diameter : 800mm, Weight : 250kg

Core Diameter Feeder
3 inch

Operational Environment

Temperature
Operating: 20°C~25°C(68°F~77°F)

Humidity
Operating: 45~65%

* Environmental influences can affect print quality.

Others

Rip Software
Ergosoft, Caldera

Air Supply Specifications
Supply Pressure: 4 bar
Flow Rate: 6 m³/h
Air Connection Tube Diameter: ø8 (O.D.)

Dimensions / Weight

Printer
5,697(W) x 1,405(D) x 2,288(H) mm, 2,960kg

Sub Plate
3,800(W) x 590(D) x 210(H) mm, 116kg

Winder
2,100(W) x 847(D) x 1,415(H) mm, 300kg

Fume Buster
755(W) x 692(D) x 1,588(H) mm, 270kg

Heatman Pro Grande
4,675(W) x 1,154(D) x 1,410(H) mm, 950kg

Size based on connection structure

(1) Printer+Sub Plate+Winder
5,697(W) x 2,611(D) x 2,288(H) mm

(2) Printer+Sub Plate+Heatman Pro Grande+Winder
5,697(W) x 3,934(D) x 2,288(H) mm

(3)Option Unwinder+Printer+Sub Plate+Heatman Pro Grande+Option Winder
5,697(W) x 5,240(D) x 2,288(H) mm

Electricity

Printer
19kW 3Φ AC 380V, 29A

Winder
0.4kW 1Φ AC 220V, 2A

Fume Buster
1.3kW 1Φ AC 220V, 6A

Heatman Pro Grande
28kW 3Φ AC 380V, 43A

Revolutionary 3.2m Printing,
Grande Scale, Supreme Velocity

ARTEMIS GRANDE

Sales Performance of DGI 3.2m Wide-Format Printers

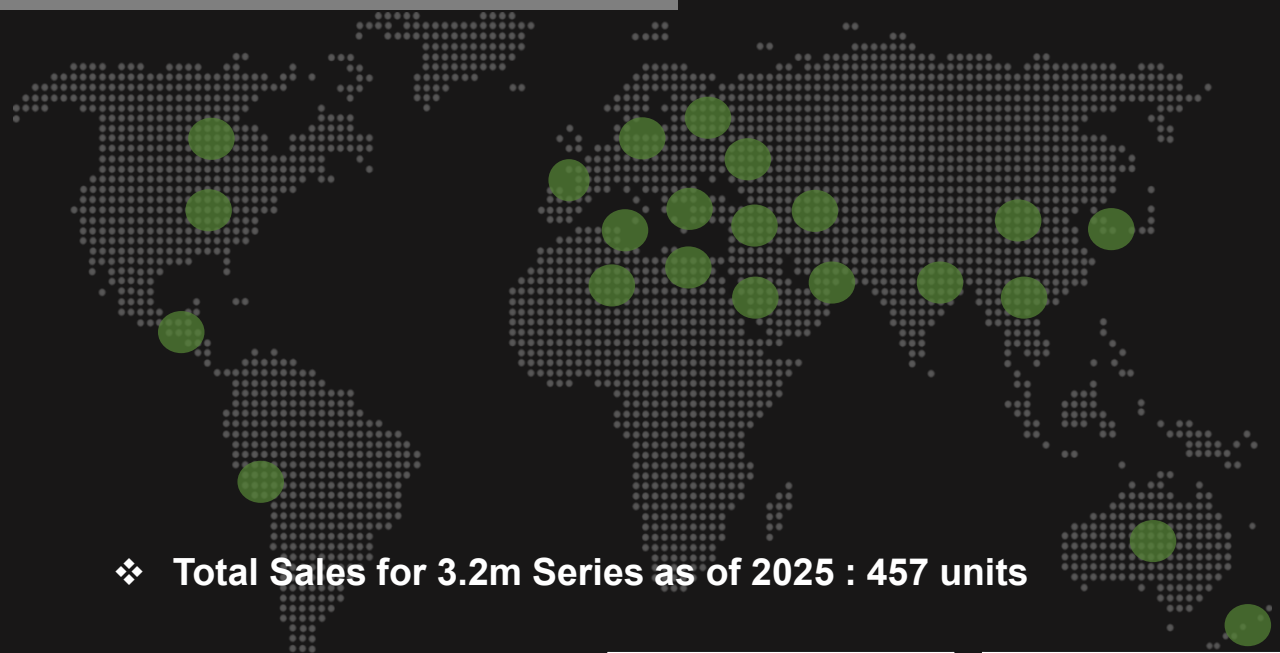

❖ Total Sales for 3.2m Series as of 2025 : 457 units

Asia	
South Korea	21
Australia	8
China	6
India	7
New Zealand	1
Philippines	1
Singapore	1
Thailand	7
Total	51

Europe			
Belgium	68	Poland	10
Bulgaria	10	Portugal	22
Croatia	1	Slovakia	1
Finland	2	Spain	4
France	6	Sweden	2
Germany	9	Türkiye	4
Italy	15	UK	13
Latvia	1	Serbia	2
Lithuania	2		
Netherlands	1		
Total	173		

Middle East + Africa	
Egypt	1
Iran	4
Iraq	20
Kenya	2
Lebanon	17
Saudi Arabia	27
Tunisia	1
UAE	30
Total	102

North America	
Canada	4
USA	121
Total	125

South America	
Chile	2
Mexico	3
Total	5

Revolutionary 3.2m Printing,
Grande Scale, Supreme Velocity

ARTEMIS GRANDE

Spec Comparison

Item		Artemis Grande				Teleios Grande G5		Teleios Grande H12	
Head		RICOH GEN5				RICOH GEN5		RICOH GEN5	
Color		4		6/8 (SPC Available)		4		6 (SPC Available)	
Print Speed	2 Pass	200m ² /h	Production 360x1200 Quality 720x1200			154m ² /h	Production 360x1200 Quality 720x1200	143m ² /h	Production 400x1200 Quality 600x1200
	3 Pass	160m ² /h	Production 360x1800 Quality 720x1200	150m ² /h	Production 360x900 Quality 600x900	119m ² /h	Production 360x1800 Quality 720x1200	98m ² /h	Production 400x1800 Quality 600x1800
	4 Pass	120m ² /h	Production 360x2400 Quality 720x2400	115m ² /h	Production 360x1200 Quality 600x1200	90m ² /h	Production 360x2400 Quality 720x2400	78m ² /h	Production 400x2400 Quality 600x2400
	6 Pass			76m ² /h	Production 360x1800 Quality 600x1200	-		-	
	8 Pass			58m ² /h	Production 360x2400 Quality 600x2400	-		-	
Media Width		3,250mm				3,250mm		3,250mm	
Head Arrangement		4 Heads per row (3 rows)				4 Heads per row (2 rows)		6 Heads per row (2 rows)	
Media Weight		350mm/150kg Optional : 800mm/250kg				350mm/150kg		280mm/150kg	
Dimension (mm)		5,697*1,405*2,288				5814(W)*1167(D)*1720(H)		5014(W)*1150(D)*1665(H)	
Tension Control System		Cylinder Press roller				2 nd roller(Servo motor)		Fabric Press Roller	
Carriage Motor Type		Linear motion / Magnetic type (Precision & Stability)				Belt / Encoder strip type		Linear motion / Magnetic type	
Head Height Adjustment		Z-axis (1mm ~ Max 20mm) (Ultimate Media Versatility)				Z-axis (1mm ~ Max 10mm)		Manual(L : 2mm, M : 3mm, H : 4mm)	
Tension Roller Type		Cylinder type				Weight type		Cylinder type	
Dust Protection		(1) Carriage Fan (2) Dust removal devices(2ea)				None		(1) Printer Rear Cover Fan (2) Dust removal device(1ea)	
Dryer Performance		Front: 7.5kw / Rear: 5kw / Distance : 410mm (Powerful Dual Dryer)				1kw*6ea = 6kw / Distance : 650mm		1kw*6ea = 6kw / Distance : 350mm	
Exterior		Covered				Without Cover		Covered	
Auto-Cleaning System		Single Blade				None		Dual Wiper	
Individual Print Mode		Row1, Row2, Row3				Row 1, Row 2		Row 1, Row 2	
Power Specifications		3-Phase, AC380V, 18kw				3-Phase, AC380V, 13.4kw		3-Phase, AC380V, 13.8kw	
Remote Monitoring Industry 4.0		DGI Monitoring Center DMC (Smart Operation)				None		None	

User friendly

- Fast customer service and Easy and accurate parts ordering

The screenshot displays the D-Shop ordering system interface. At the top, the DGI logo is on the left, and navigation links for 'Products list', 'Goods list', 'Parts list', and 'Order Status' are in the center. On the right, there are icons for a shopping cart, a user profile, and a language selector set to 'ENG'. Below the navigation is a large banner with the text 'D-Shop ordering system'. Underneath the banner, a breadcrumb trail reads 'HOME > Menu list'. The main content area features four large, square buttons arranged in a row. Each button has a large letter and a diagonal slash, followed by the category name: 'E / EQUIPMENT ORDER' (with an image of an APOLLON printer), 'I / INK ORDER' (with an image of four ColorWater ink bottles), 'P / ORDER PARTS' (with an image of a printer cartridge), and 'L / ORDER LIST' (with an image of a hand pointing at a laptop screen). At the bottom of the interface, contact information is provided: Address 52, Cheongdam-ro, Yangju-si, Gyeonggi-do, 11459, Rep. of KOREA; Tel. (82)-(31) 820 - 8900; Fax : (82)-(31) 820-8980&; email : dgisupport@dgi-net.com; Company Registration Number : 127-81-18162; CEO : CHOI DONG HO; and COPYRIGHT (C) DGI 2019. All Rights Reserved.

Revolutionary 3.2m Printing,
Grande Scale, Supreme Velocity

ARTEMIS GRANDE